

Portable Filter Carts

Models 5MFP & 10MFP with Moduflow™ *Plus*
and Intelli-Cart™



ENGINEERING YOUR SUCCESS.

Portable Filter Carts

Applications

- **Filtering new fluid before putting into service**
- **Transferring fluid from drums or storage tanks to system reservoirs**
- **Conditioning fluid that is already in use**
- **Complimenting existing system filtration**
- **Removing free and emulsified water from a system**
- **For use with fluids such as hydraulic, gear and lube oils**

Parker portable filter carts are the ideal way to prefilter and transfer fluids into reservoirs or to clean up existing systems.

Fluid should always be filtered before being put into use. New fluid is not necessarily clean fluid. Most new fluids (right out of the drum) are unfit for use due to high initial contamination levels. Contamination, both particulate and water, may be added to a new fluid during processing, mixing, handling and storage.

Water is removed by installing Par-Gel™ elements in the outlet filter. Par-Gel™ elements are made from a polymer which has a very high affinity for free water.

Once water comes into contact with this material, it is removed from the system.

The Parker portable filter cart uses two high capacity ModuFlow™ Plus filters for long element life and better system protection. The first stage (inlet) filter captures larger particles, while the second stage (outlet) filter captures finer particles or removes water. A rugged industrial quality gear pump gets the job done fast.

Using a Parker portable filter cart is the most economical way to protect your system from the harm that can be caused by contamination.

Features	Advantages	Benefits
Two filters instead of one w/ 2.5 times increased dirt holding capacity	Pump protection and long element life	Element cost savings and trouble-free service
Wide variety of particulate elements available	Capable of getting a fluid to a desired cleanliness level	Extends fluid life and system performance
Par-Gel™ water removal elements available	Removes “free water” from a system	Gets dirt and water out of system with one process
Heavy duty frame	Rugged and durable	Built to last
Lightweight and portable	Easy to move from place-to-place	One person operation
Two flow rates available: 5 gpm or 10 gpm	Enables use in low or high viscosity applications	Matched to your needs
Eleven-foot hose and wand assemblies included	Additional hardware not necessary	Ready to use as received

Portable Filter Carts

Features

Hose & wand assembly

- Ready to use; no additional hardware needed
- Flexible hoses for tight spots
- Kink-resistant hose prevents pump cavitation

icountPD (Intelli-Cart™ option)

- Early warning LED or digital display indicators for Low, Medium and High contamination levels
- Self diagnostic software

Service cover

- Top-accessible for easy changing of elements

Electrical Cord

- 6 ft. with ON/OFF switch
- Optional 20 ft. cord with retractable reel & mounted power switch with thermal overload protection

Visual indicator

- Tells you when to change element

Heavy Duty frame

- Rugged and built to last

Dual filters

- Two stage, double length filtration for long element life and pump protection

110V/220V AC motor

- Industrial brand name

Elements (not shown)

- Available for both particulate and Water Removal (WR) in double length w/ 2.5 times increased dirt holding capacity

Gear pump

- Industrial quality
- Quiet operation
- Dependable, long life

Drip tray

- Helps keep the work area safe and clean

Portable Filter Carts

Specifications

Maximum Recommended Fluid

Viscosity:

5MFP – 3000 SUS (647cSt)
0.85 specific gravity

10MFP – 500 SUS (108 cSt)
0.85 specific gravity

Visual Indicator (outlet filter):

Visual differential type
3-band (clean, change, bypass)

Filter Bypass Valve Settings

(Integral to Element):

Inlet – 3 psid (0.2 bar)
Outlet – 35 psid (2.4 bar)

Operating Temperature:

Seal option “B” (standard)
-40°F to +150°F (-40°C to +66°C)

Electrical Service Required:

5MFP – 110/220 volts, 60/50
Hz, single phase, 8/4 amps
10MFP – 110/220 volts, 60/50
Hz, single phase, 10/5 amps

Electrical Motor:

5MFP – ½ hp @ 1725 rpm,
Open, Drip Proof
10MFP – ¾ hp @ 3450 rpm,
Open, Drip Proof
Thermal overload protection

Construction:

Cart frame – Steel
Filter head – Aluminum
Filter bowl – Steel
Hoses – PVC (Std.)
EPDM (high temp option)
Wands – PVC (Std.)
Steel tube (high temp
option)

Weight:

110 lbs. (45.4kg)



Dimensions:

A = Height: 1034mm (40.7 in.)
B = Width: 648mm (25.5 in.)
C = Depth: 503mm (19.8 in.)

New feature!

Intelli-Cart™

Parker is pleased to announce its R&D effort to offer a diagnostic filter cart - the Intelli-Cart. The icountPD particle detector, the most up-to-date technology in solid particle detection, can be mounted to the standard frame of the filter cart for enhanced monitoring of your hydraulic system. The icountPD, coupled with the filter cart is a cost effective solution to fluid management and contamination control. Ask your sales representative today for more information.

Typical Fluid Cleanliness Level Requirements

Many manufacturers of hydraulic components have established fluid cleanliness levels for their components. Using a portable filter cart can be a very effective way to reach and maintain these cleanliness levels.

Component	ISO Cleanliness Level
Servo control valves	16/14/11
Proportional valves	17/15/12
Vane and piston pumps/motors	18/16/13
Directional and pressure control valves	18/16/13
Gear pumps/motors	19/17/14
Flow control valves/cylinders	20/18/15
New fluid	20/18/15

Filter Cart Element Performance

Media Code	Filter Media	Capacity (grams)
40W	Woven Wire	*
40SA	Synthetic	*
20Q	Microglass	140
10Q	Microglass	135
05Q	Microglass	130
02Q	Microglass	110

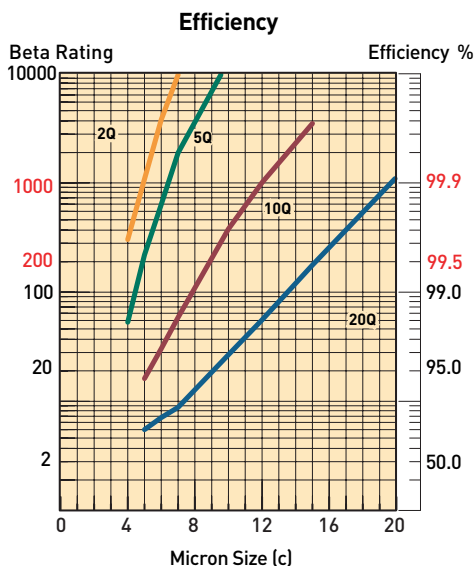

Notes: Multipass test run @ 80 gpm to 50 psid terminal - 5 mg/l BUGL.

Filter Cart Performance

Fluid cleanliness levels are a function of initial contamination levels, contamination ingress rates, reservoir size and filter element efficiency. The chart below lists approximate time requirements to achieve certain cleanliness levels based on the assumptions noted.

Reservoir Capacity (Gallons)	Time Required (Hours)	Projected Cleanliness Level (ISO)
50	0.5	20/18/15
50	1.0	17/15/12
50	2.5	16/14/11
100	1.5	18/16/13
100	2.5	17/15/12
100	4.0	16/14/11
200	2.5	19/17/14
200	3.5	18/16/13
200	5.0	17/15/12

Notes:

The results in the chart are based on the following assumption:

1. Initial contamination level is 500,000 particles greater than 10 micrometers per 100 ml of fluid (10MFP cart).
2. Inlet filter fitted with 40SA element; outlet with 20Q element.
3. System ingress rate equal to 1×10^6 particles greater than 10 micrometers entering the system per minute.

The Intelli-Cart™ with particle detector provides an excellent method for filtering and trending contamination levels.

For optimum particle detector performance results when monitoring contamination levels, fluid viscosity range should be 50 - 250 SUS.

Par-Gel™ Media Water Capacity

Model	Fluid Viscosity	Capacity
5MFP	75 SUS	600 ml
	200 SUS	420 ml
10MFP	75 SUS	500 ml
	200 SUS	300 ml

Notes:

1. Par-Gel™ elements are designed to remove “free water”, which is defined as water that is above a particular fluid’s saturation level.
2. Capacity is very dependent on flow rate and viscosity. Not recommended with fluids in excess of 500 SUS.

Assembly

1. Install hoses to inlet and outlet filters by threading the hose end with the straight thread o-ring seal fitting into the filter flange.
2. Connect the PVC tube wands to the swivel fitting on the hose end. When servicing the PVC tube wand, do not over-torque the metal fittings going into the PVC coupling. Over-torque will result in cracking the coupling. Generally, 1/4 turn beyond hand-tight is sufficient.
3. The Intelli-Cart™ is shipped with a bag that contains user manuals, iPD programming disk, and accessory parts.
4. The iPD is shipped with the factory default setting. Users can reprogram the iPD with the cable located in the attached bag, the program disk and the iPD owners manual.

Operating Instructions

1. Insert the inlet wand assembly into the supply fluid receptacle (drum/reservoir). The RFP filter is the inlet filter.
2. Insert the outlet wand assembly into the clean fluid receptacle (drum/reservoir). The ILP filter is the outlet filter.
3. Verify that the ON/OFF switch is OFF and plug the cord into the proper grounded power source (3 wire).
4. Turn switch to ON position and check outlet wand for oil flow. Allow 30 to 60 seconds for filters to fill with oil. If repeated attempts to obtain oil flow fail, check pump inlet fittings for tightness, remove inlet filter access cover and verify the cover sealing o-ring is in place. For very viscous fluids it may be necessary to pour 1 or 2 quarts of fluid into the RFP inlet filter housing to prime pump initially.
5. The condition of the filter element should be monitored by observing the cleanliness indicator on the outlet filter. When the indicator is in the CHANGE position, both inlet and outlet filter elements MUST be replaced to prevent fluid from going through the bypass in the filters.

6. The inlet filter element is provided with a 3PSI bypass spring, and prevents the pump from cavitating if the element is not changed. The outlet filter element is provided with a 35PSI bypass spring to prevent excessive pressure which may be harmful to personnel or to the filter cart.

Warning: The filter bypass spring acts as a relief valve for the pump. Do not restrict the outlet hose with a shut-off valve which will defeat the function of the bypass valve, causing excessive pressure, which may be harmful to personnel or to the filter cart.

7. The cleanliness indicator works on differential pressure and will indicate the condition of the element (CLEAN, CHANGE, or BYPASS).

NOTE: The filter cart must be in operation for the indicator to read properly.

Maintenance Instructions

1. Turn switch to OFF position and unplug cord from electrical outlet.
2. Remove tube wands from oil to prevent siphoning.

3. Loosen hex head screws on filter cover. Turn cover to clear screws, remove cover.
4. Pull filter element from the filter head.
 - a) Replace the synthetic or Microglass elements. Verify correct element replacement.
 - b) Wire mesh elements can be cleaned. Ultrasonic cleaners provide best results.
5. Install element in filter housing. Make sure element o-rings seat properly into the head, making sure that the notch on the element lines up with the notch in the head.
6. Inspect the cover o-ring and replace if necessary.
7. Replace cover and tighten hex head screws until they are snug. Do not over-torque (16 - 19 Ft. Lbs.) these screws. Do not interchange the inlet filter cover with the outlet filter cover. (The inlet filter has a "RFP" prefix, the outlet filter has a "ILP" prefix).
8. Contact the HFD service department at 419-644-0259 regarding iPD calibration.
9. iPD removal: remove oil lines from the iPD at the two fittings closest to the iPD. Disconnect the two cables from the iPD. Remove iPD from cart via two screws. The cart can be used without the iPD as long as the sample hoses are removed from the System 20. Protect sampling connectors from contamination.

Problem	Cause	Solution
Does not start	<ul style="list-style-type: none"> • ON/OFF Switch • No electrical power • Defective motor 	<ul style="list-style-type: none"> • Turn switch ON, replace switch if defective • Plug in cart • Replace
No oil flow or erratic pump noise	<ul style="list-style-type: none"> • Filter housing not filled with oil • Suction leak • Defective pump 	<ul style="list-style-type: none"> • Allow pump to run 30 to 60 seconds • Check tightness of inlet fittings • Check o-ring in inlet filter cover for nicks • Kink or restriction in inlet hose • Add 1 or 2 quarts of oil to inlet filter • Replace pump
Indicator reads CHANGE or BYPASS	<ul style="list-style-type: none"> • Element dirty • Oil extremely cold or viscous 	<ul style="list-style-type: none"> • Replace or clean elements (both filters) • Change element to coarser micron rating
Indicator does not seem to move	<ul style="list-style-type: none"> • No outlet element • 40 micron element installed in outlet filter 	<ul style="list-style-type: none"> • Install element • Check cart model number to verify correct element. The inlet filter has a rating RFP prefix; the outlet filter has an ILP prefix

Filter Cart Replacement Parts

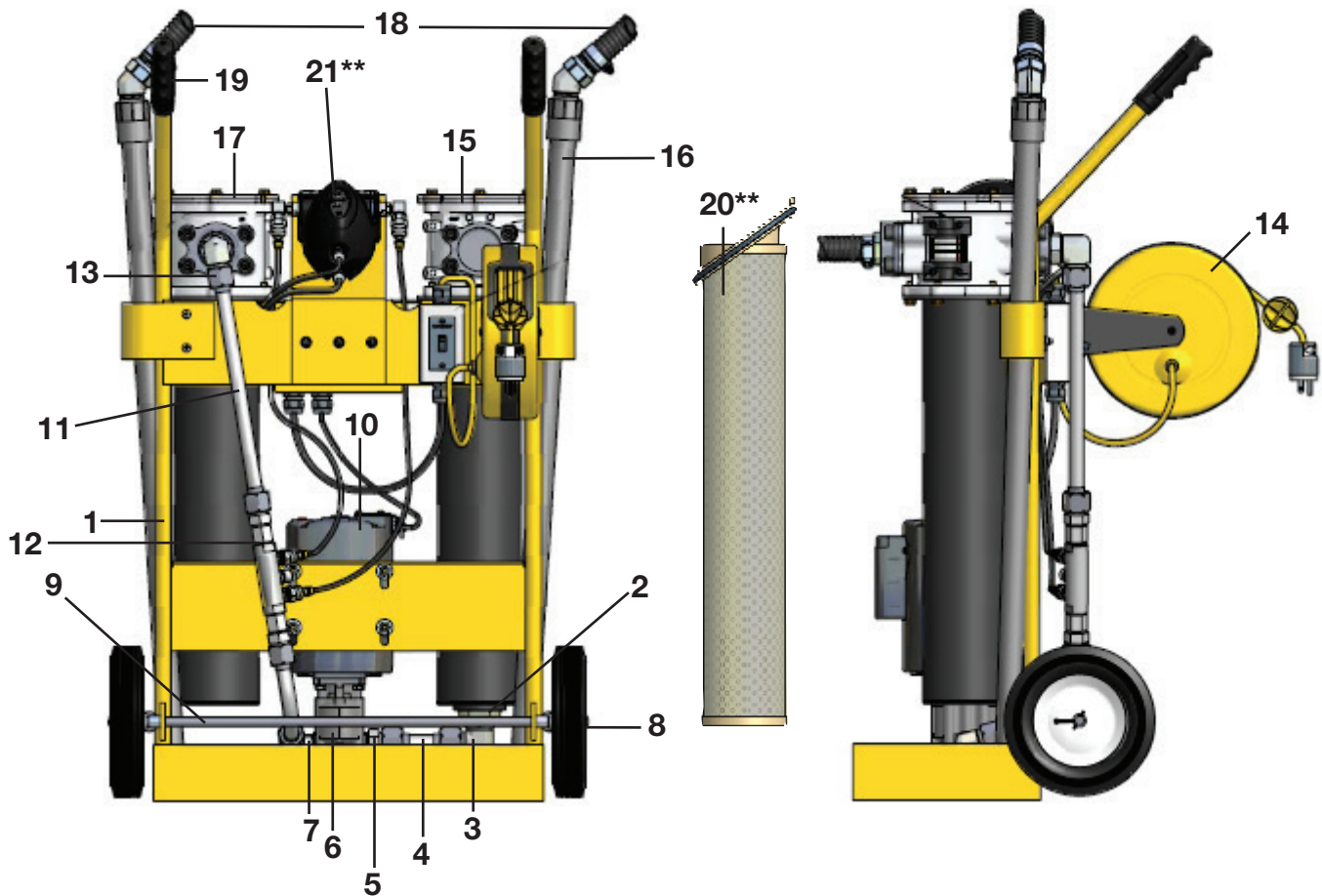

Item No.	Part No.	Description	Qty
1	942419	Frame	1
1	941468	Frame (Intelli-Cart™)	1
2	940980	Pipe Reducer Fitting	1
3	940979	Tube Fitting	1
4	937526	Suction Tube Assy.	1
5	928652	Adapter Fitting	1
6	928731	Pump	1
7	940977	Adapter Fitting	1
8	928650	Wheel	2
9	928653	Axle	1
10	941766	Motor 10MFP	1
10	941767	Motor 5MFP	1
11	941922	Discharge Tube Assy.	1
12	941467	Discharge Tube Top (Intelli-Cart™)	1
	941466	Discharge Tube Bottom (Intelli-Cart™)	1
	STI.0144.100	System 20 (Intelli-Cart™)	1
	3/8-8F40HG5S	System 20 Fitting 1 (Intelli-Cart™)	2
	12/8 F50X-S	System 20 Fitting 2 (Intelli-Cart™)	2

Item No.	Part No.	Description	Qty
13	940978	Tube Fitting	1
14	928623	Cord Reel	1
15	941665	Inlet Filter – Nitrile	1
15	941908	Inlet Filter – Fluorocarbon	1
16	928784	Tube Wand Assy. – Seal Option B	2
17	941666	Outlet Filter – Nitrile	1
17	941909	Outlet Filter – Fluorocarbon	1
18	945582	Hose Assy. – Seal Option B	2
19	928651	Handle Grip	2
20	See Chart**	Element, (1) Inlet & (1) Outlet	2
21	See Chart**	icountPD (Intelli-Cart™)	1
	B84654	icount Cable (Intelli-Cart™)	1
	B84224	icount Hoses (Intelli-Cart™)	2
	2/2A40EG4M-S	icount Fitting 1 (Intelli-Cart™)	2
	EMA3/1/8ED	icount Fitting 2 (Intelli-Cart™)	2

**Refer to chart on How to Order page.

5MFP, 10MFP and Intelli-Cart

Portable Filter Carts

How To Order

Select the desired symbol (in the correct position) to construct a model code.

Example:

BOX 1	BOX 2	BOX 3	BOX 4	BOX 5	BOX 6	BOX 7	BOX 8
10MFP	2	40SA	10Q	B	VP	I	1

BOX 1: Filter Series	
Symbol	Description
5MFP	5 GPM (3000 SUS max)
10MFP	10 GPM (500 SUS max)

BOX 2: Element Length	
Symbol	Description
2	Double

BOX 3: Inlet Filter Element	
Symbol	Description
40SA	Synthetic, 40 micron
40W	Stainless steel mesh, 40 micron nominal
20Q ¹	Microglass, 20 micron

BOX 4: Outlet Filter Element	
Symbol	Description
02Q	Microglass, 2 micron
05Q	Microglass, 5 micron
10Q	Microglass, 10 micron
20Q	Microglass, 20 micron
WR	Par-Gel™ Water Removal

BOX 5: Seals	
Symbol	Description
B	Nitrile

BOX 6: Indicator	
Symbol	Description
VP	Visual indicator, 3-band (mounted on outlet filter only)

BOX 7: Bypass	
Symbol	Description
I	35 PSID (2.4 bar) (outlet filter element)

BOX 8: Options	
Symbol	Description
1	None
6 ²	20' electrical cord (retractable reel)
9	Visual indicator on inlet filter
PD ³	iPD w/ standard LED display
PDL ³	iPD w/ LCD display and integrated Moisture Sensor

Notes:

1. Only available in 5MFP configuration
2. Standard with option PD or PDL
3. Only available in 10MFP configuration

Please note the bolded options reflect standard options with a reduced lead time.

Replacement Elements

Media	Nitrile Seals		Fluorocarbon Seals	
	Inlet Filter (3 psid integral bypass)	Outlet Filter (35 psid integral bypass)	Inlet Filter (3 psid integral bypass)	Outlet Filter (35 psid integral bypass)
02Q	N/A	937397Q	N/A	937405Q
05Q	N/A	937398Q	N/A	937406Q
10Q	N/A	937399Q	N/A	937407Q
20Q	940971Q	937400Q	940974Q	937408Q
40SA	940802	N/A	940972	N/A
40W	940803	N/A	940973	N/A
WR	N/A	940734	N/A	940736